



INSTALLATION ESTIMATED IN 1 HOUR AND A HALF

 SUBARU	SUBARU	PLUG AND PLAY CBL059SBDB11	PROTOCOL RESISTIVE
---	---------------	---------------------------------------	-------------------------------

Vehicle	Year	OEM Radio
Forester	2007-2008	All models (Without Navigation)
Impreza	2006-2008	All models (Without Navigation)
Impreza	2009->	All models (Without Navigation)
Outback	2010->	All models (Without Navigation)
Trezia	2011->	All models (Without Navigation)
XV	2012->	All models (Without Navigation)

Connector position: Radio location	ANTENNA ADAPTER
Back the radio compartment is located the OEM radio connector 	Code: K54ADA9014/22 

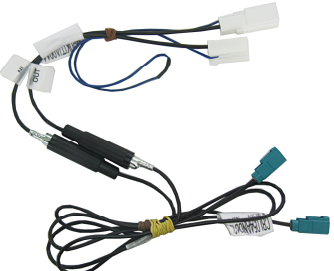
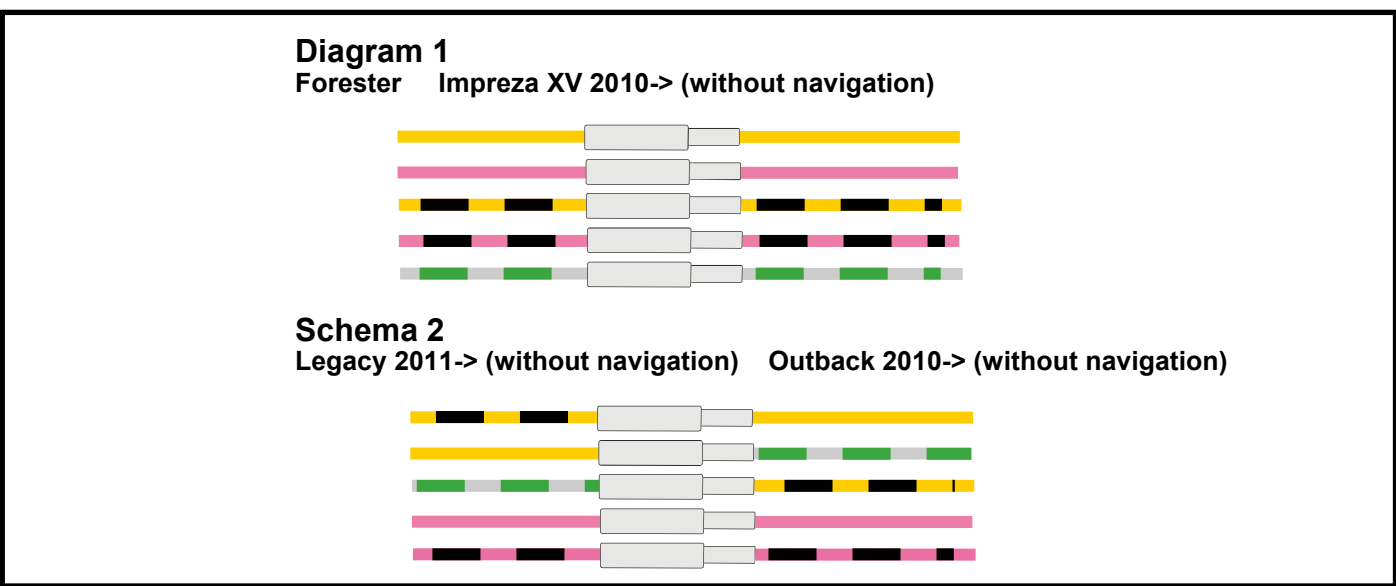
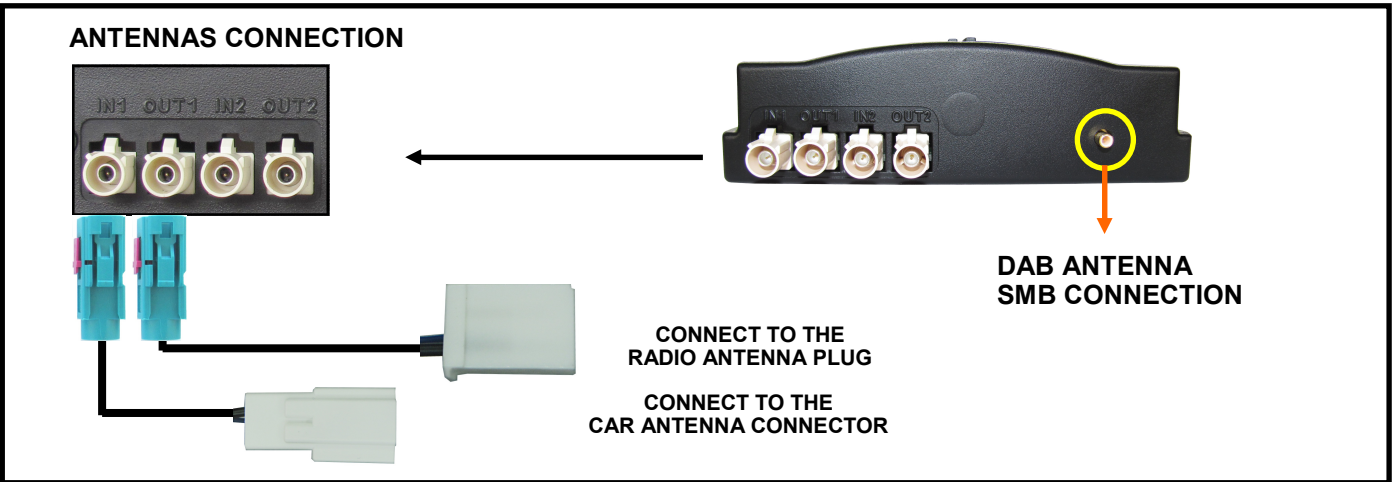

NOTE

TUNES ON THE RADIO THE DEFAULT FM STATION AND MEMORIZE THE FREQUENCY 87.7 mhz IN ONE OF THE FREE CHANNEL (EXAMPLE POSITION 1). POWER THE MEDIADAB HD, IT WILL START ON, IT SHOULD APPEAR THE **SCAN** OPERATION. IT TAKES SOME MINUTES. TO MAKE THIS BE SURE THAT THE CAR IS IN AN OPEN SPACE AND THE DAB ANTENNA IS CORRECTLY CONNECTED. ONCE SCAN IS END THE FIRST DAB STATION AVAILABLE SHOULD PLAY.

STERING WHEEL PROGRAMMING PROCEDURE



ATTENTION

BEFORE STARTING THE STEERING WHEEL COMMANDS LEARNING PROCEDURE PLEASE CHECK THAT THE OEM RADIO IS CONNECTED AND THE KEY IS TURNED ON LEARNING PROCEDURE IS ALLOWED ONLY FOR 60 SECONDS AFTER INTERFACE POWER ON.
IF THE INTERFACE WILL NOT RECOGNIZE STEERING WHEEL BUTTONS IS NECESSARY TO REMOVE AND CONNECTED BACK AGAIN POWER.

PRESS VOLUME — THE LED BECOMES ORANGE: PLEASE KEEP IT PRESSED FOR 1 SECOND AND RELEASE IT WHEN THE LED IS RED



PRESS VOLUME + THE LED BECOMES ORANGE: PLEASE KEEP IT PRESSED FOR 1 SECOND AND RELEASE IT WHEN THE LED IS RED



PRESS SEEK — THE LED BECOMES ORANGE: PLEASE KEEP IT PRESSED FOR 1 SECOND AND RELEASE IT WHEN THE LED IS RED



PRESS SEEK + THE LED BECOMES ORANGE: PLEASE KEEP IT PRESS FOR 1 SECOND AND RELEASE IT WHEN THE LED IS RED



PRESS MODE THE LED BECOMES ORANGE: PLEASE KEEP IT PRESS FOR 1 SECOND AND RELEASE IT WHEN THE LED IS RED



PRESS QUICKLY THE BUTTON OF MEDIADAB TO JUMP MUTE FUNCTION, LED BECOMES ORANGE AND TURNS IMMEDIATELY RED



PRESS VOICE THE LED BECOMES ORANGE: PLEASE KEEP IT PRESS FOR 1 SECOND AND RELEASE IT WHEN THE LED IS RED



PRESS PHONE UP THE LED BECOMES ORANGE: PLEASE KEEP IT PRESS FOR 1 SECOND AND RELEASE IT WHEN THE LED IS RED



PRESS PHONE DOWN THE LED BECOMES ORANGE: PLEASE KEEP IT PRESSED TILL THE LED IS GREEN



THE LEARNING PROCEDURE IS FINISHED.



In case of an incorrect working of the steering wheel commands functions, please make a RESET of the module, as described below, by pressing the button of the unit till the LED of the module switches OFF.





SUBARU

PLUG AND PLAY
CBL059SBDB11

PROTOCOL
RESISTIVE

QUICK MENU

SWITCH ON
VOLUME
SEQUENCE



VOL+



VOL-



VOL+



VOL-

SWITCH OFF
VOLUME
SEQUENCE



VOL+



VOL-



VOL+



VOL-

OR TROUGH THE MENU

ENTER MENU'
SOURCE
SEQUENCE



PRESS MODE LONG

MENU'
NAVIGATION
SEEKS

PREVIOUS
SEEK —



NEXT
SEEK +

CONFIRM A
MENU
SELECTION
PRESS
MODE

SHORT
PRESS



CHANGE
CHANNEL
THROUGH SEEK

PREVIOUS
SEEK —



NEXT
SEEK +

CHANGE
FAVOURITE
CHANNEL
THROUGH SEEK

LONG PRESS
PREVIOUS
CHANNEL



LONG PRESS
NEXT
CHANNEL

ADD FAVOURITE
CHANNEL
VOLUME
SEQUENCE



VOL-



VOL+

SCAN

PRESS
MODE
3 TIMES

